



ESTACA
ÉCOLE D'INGÉNIEURS



The use and benefits of Functional Size Measurement in the context of AUTOSAR

Hassan Soubra, Eng., Ph.D



UKSMA, November 8th 2012, London

Agenda

- **Context**
- **Autosar (AUTomotive Open System Architecture)**
- **Functional Size Measurement with AUTOSAR**
- **Conclusions**



Context: Embedded Systems in cars

- **Today's cars are more computarized than the Apollo space shuttle that landed the first humans on the moon... and the use of E/E systems in cars is continuously growing!**
- **E/E systems are complex systems, composed of ECUs that are interconnected by a network, in which software plays an ever more important role.**
- **Software reuse and carryover techniques have become inevitable for OEM.**



AUTomotive Open System Architecture 1

BMW Group



Continental



TOYOTA

PSA PEUGEOT CITROËN



BOSCH

A General Motors Company

OPEL

VOLKSWAGEN AG

DAIMLER

AUTOSAR

Cooperate on standards

Standardized
application
interfaces

Standardized
software
architecture

Standardized
configuration
processes

Compete on implementation



AUTomotive Open System Architecture 2

- System engineering approach with a **layered architecture**.
- **Standardization** and distribution of functions.
- Principle of **Reuse** and configuration.
- <http://www.autosar.org/>



AUTomotive Open System Architecture 3

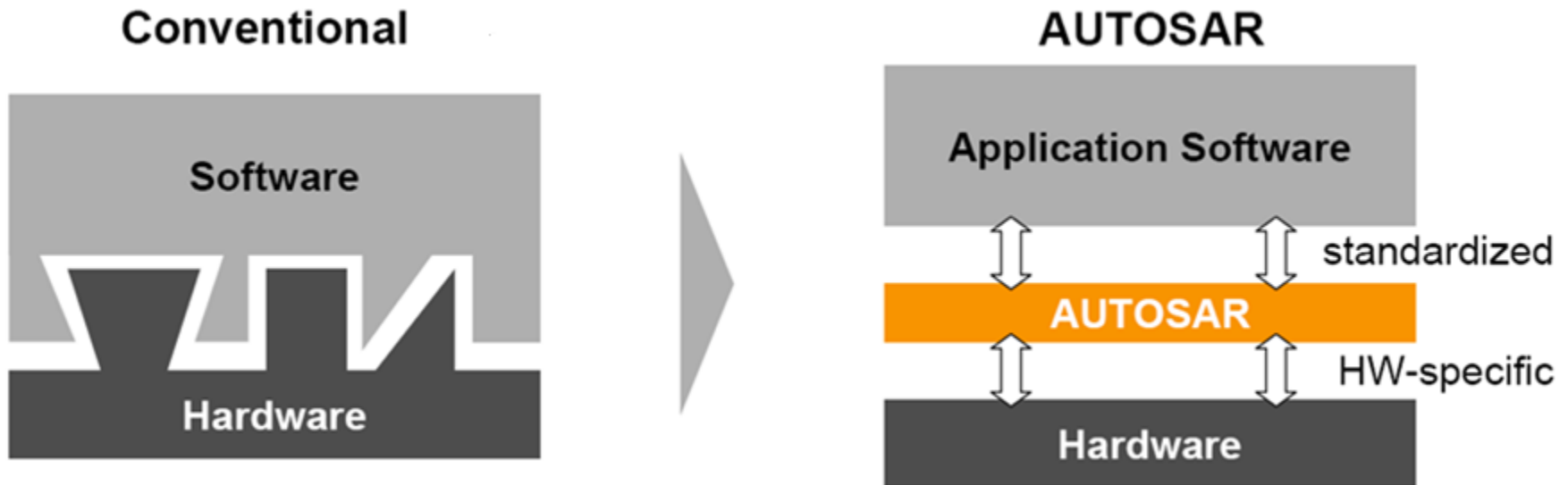

- Software is widely **independant** of Hardware.
- **Time** and **costs** are **reduced** due to the simplification of the development processes.
- **Quality** and **efficiency** are **enhanced** because of software reuse at OEM and suppliers.

Functional Size Measurement

- FSM is a powerful tool providing an objective and quantitative base for managing software projects: estimation models, effort models, benchmark models, and quality models...
- FSM methods (e.g. COSMIC) are applicable at both the beginning of the development process, in the requirements specification phase, and at the end of the project, after implementation for benchmarking studies.



FSM with AUTOSAR 1

- FSM-based effort/cost estimation models are used for predicting project effort and duration: FSM goes hand in hand with AUTOSAR objectives in terms of managing automotive software projects.

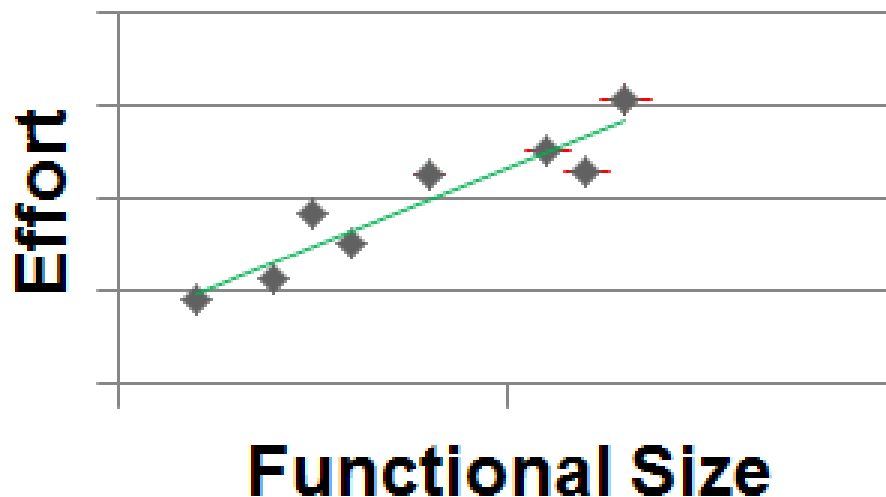

FSM with AUTOSAR 2

Some current research issues in AUTOSAR tackled with FSM at ESTACA:

- Early estimation if extra ECUs are needed - and their number- for the implementation of one or more extra application software (**Acceptance Condition**).
- Early estimation of the **Network Traffic** with different software mapping combinations.
- Early estimation of the **Processor Load** with different software mapping combinations.



FSM with AUTOSAR 3

Estimating Software Acceptance Condition for Profile 2:

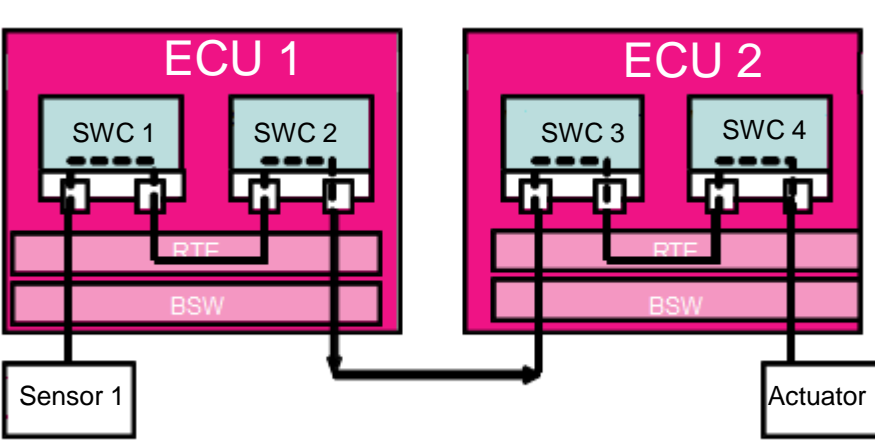

- 4 SWCs
- 2 ECUs
- 1 Sensor
- 1 Actuator

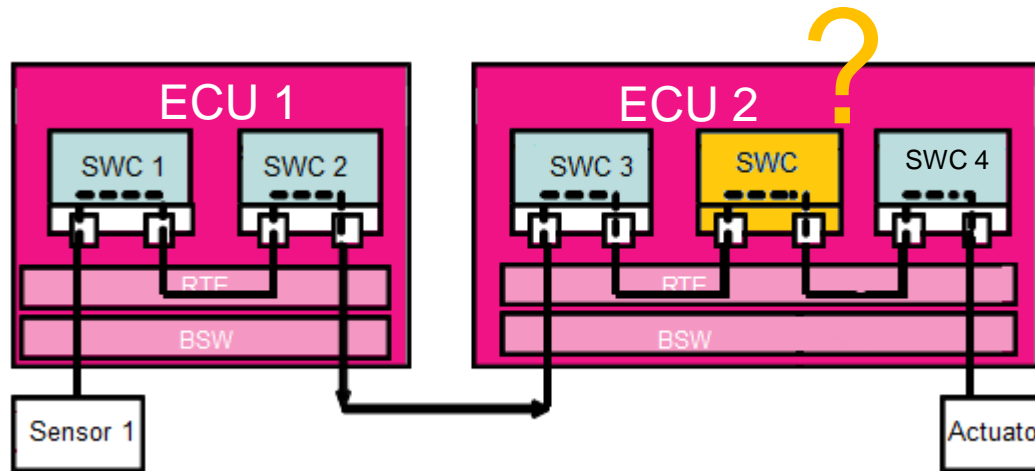
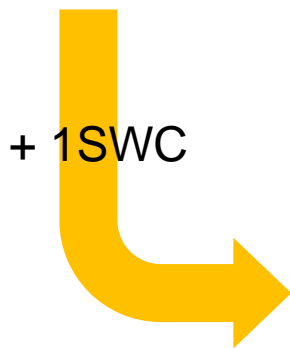

- 5 SWCs
- 2 ECUs
- 1 Sensor
- 1 Actuator

FSM with AUTOSAR 4

Acceptance Condition Estimation Model

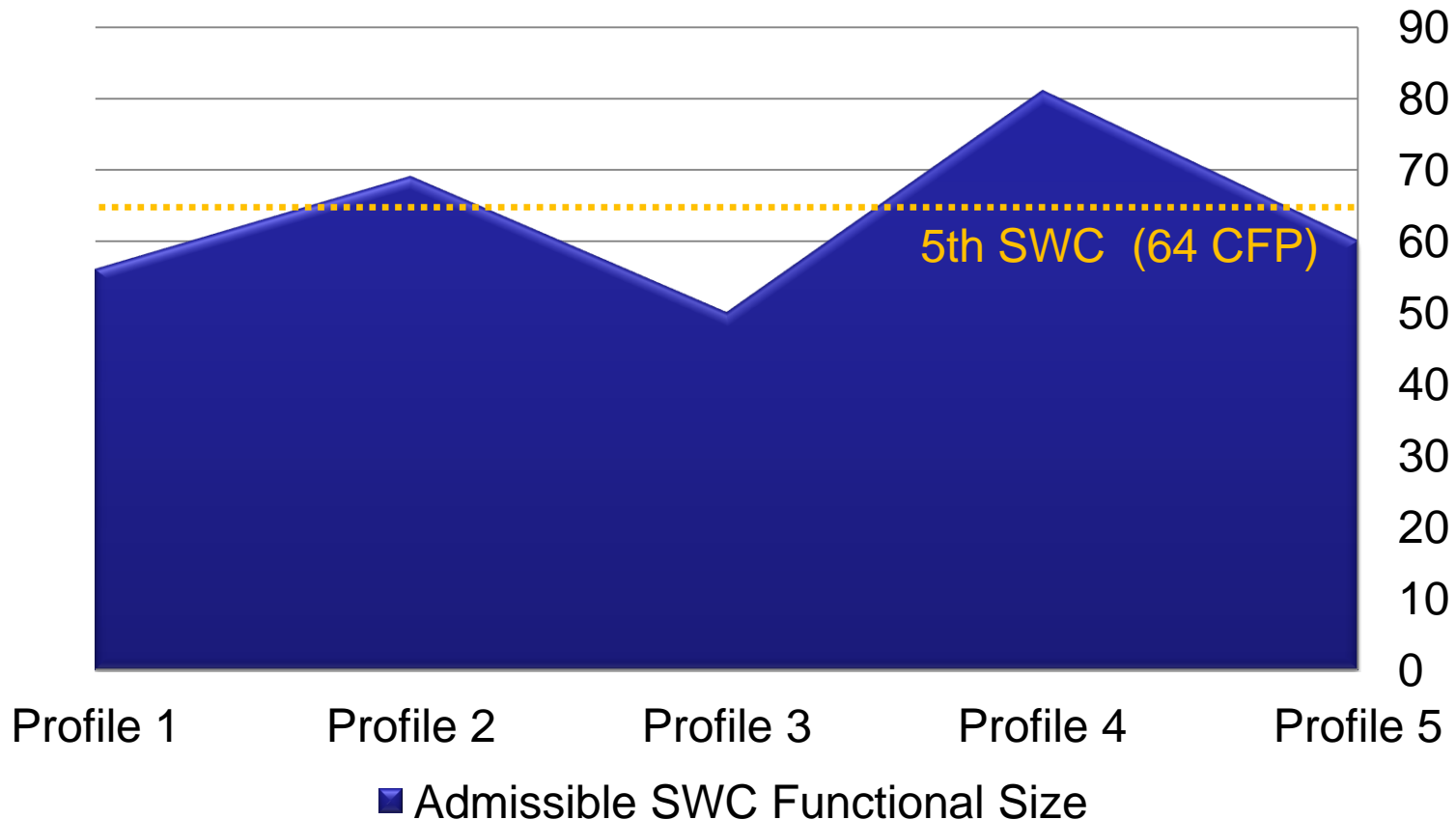

Conclusions

1. **FSM-based effort/cost estimation models go hand in hand with AUTOSAR objectives in managing automotive software projects.**
2. **FSM is a potent tool to address some indicator needs early in the software development process in the context of the AUTOSAR standard.**
3. **A high-potential research turf to answer industrial issues.**



Q & A



hassan.soubra@estaca.fr

